

If the external flexible cable or cord of this luminaire is damaged, it shall be exclusively replaced by the manufacturer or his service agent or a similar qualified person in order to avoid a hazard.

Si le câble ou le fil flexible externe de ce luminaire est endommagé, seuls le fabricant, son agent ou un technicien approuvé par l'usine sont autorisés à le remplacer afin d'éviter tout danger.

Si el exterior del cable flexible o el cable de esta lampara está dañado, se sustituye exclusivamente por el fabricante, su agente de servicio o similar persona cualificada con el fin de evitar un peligro.

Falls die externe, flexible Leitung/Kabel dieser Lupenleuchte beschädigt ist, sollte es umgehend durch den Hersteller, einen Service Partner des Herstellers oder einer gleichwertig qualifizierten Person ausgetauscht werden, um auftretende Gefahren zu vermeiden.

Hvis lampens ledning skades skal den kun erstattes av produsent, forhandler eller kvalifisert personell for å unngå fare.

Om lampans ledning skadas skall den ersättas av producent eller av auktoriserad person för att undgå fara.

**LUXO**

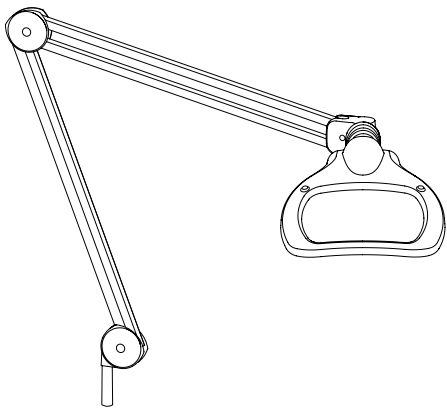

Wave LED  
2 X 6 W LED



On/off + dimming 0–50–100 %

On/off + gradation de l'intensité lumineuse 0–50–100 %

On/off + oscurecimiento 0–50–100 %

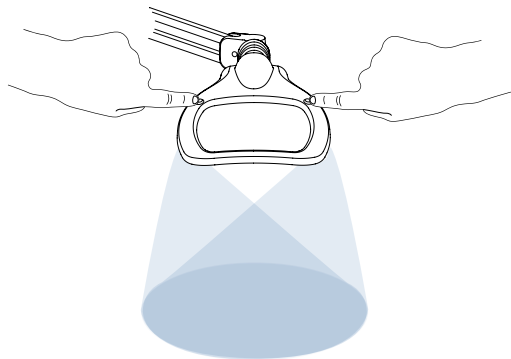

Do not clean with alcohol  
Ne pas nettoyer avec de l'alcool



No lo limpie con alcohol

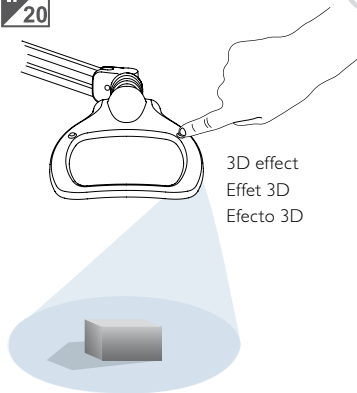

3D effect  
Effet 3D  
Efecto 3D

#### 4 HOURS AUTO SHUT-OFF

To change from 9 hours (standard) to 4 hours auto shut-off:

1 Press and hold the switch while you plug in the light

2 Light pulsates one time for confirmation

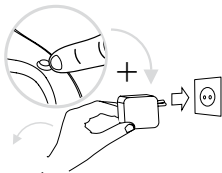

#### 9 HOURS AUTO SHUT-OFF

To change from 4 hours to 9 hours auto shut-off:

1 Press and hold the switch while you plug in the light

2 Light pulsates two times for confirmation

