









## USER AND MAINTENANCE MANUAL REMEDIAL PARALLEL BARS “PLUS”

|            |                                  |
|------------|----------------------------------|
| Art. 01325 | PARALLEL BARS PLUS 2M            |
| Art. 01326 | PARALLEL BARS PLUS 3M            |
| Art. 01327 | PARALLEL BARS PLUS 3M TILT       |
| Art. 01391 | CHILDREN’S PARALLEL BARS PLUS 2M |

**STandGOSystem®**  
Evolution Walking in Rehabilitation



### ACCESSORIES

| 01380<br>Parallel Bar Glider  | 01335 – Cart for Portable Paths<br>01379 – Set of Therapy Paths                     | 01330<br>Obstacle -divider   | 08585<br>Sensory Bags   |   |
|---|---|--|---|---|
|  |  |  |  |   |
| 08586<br>Rolls and bags   | 08587<br>Sensory Modules  | 08589<br>Hemispheres   | 08591<br>Concave - convex   | 02510<br>Set of Bags  |
|  |  |   |   |  |



## 1. GENERAL INFORMATION

### MANUFACTURER

www.chinesport.it

### PURPOSE AND CONTENT OF THESE INSTRUCTIONS

**Customers must read these instructions carefully.**

This manual provides all the necessary information for customers to use the equipment properly, safely and autonomously as well as information about equipment specification, operation, maintenance, spare parts and safety.

### EQUIPMENT DESCRIPTION AND INTENDED USE

Parallel bars allow performing rehabilitation and ambulation exercises safely.

They are made of painted steel with a thermoplastic coated handrail.

The modular parallel bars in the new PLUS LINE feature the "STandGOSystem" for the simultaneous and accurate adjustment of the handrails on both sides, keeping them perfectly parallel, by means of a single control, easy to operate.

The pedal control activates gas springs for continuous movement, ensuring the most accurate and uniform adjustment, which can be millimetric or, in any case, extremely fine. Adjustment can be performed during the rehabilitative exercise.

The distance between the handrails is easy to adjust to meet the user needs or the requirements of a specific rehabilitative exercise.

The 2- and 3-metre long basic models can be combined in various configurations to form parallel bar systems of different size: 2,3,4,5,6+ metres.

The parallel bar translation system during height adjustment makes it possible for a wheelchair person to access the handrails without the need of going up the ramp of the base platform. The handrails can also be accessed from a sitting position and adjusted afterwards to allow a patient to walk upright in a proper manner.

Specific therapy and rehabilitation paths can be created by inserting a different range of elements into the platform of the modular parallel bars. In particular, the new magnetic dividers and obstacles (item code 01330) can be quickly installed and adapted to the specific needs of a patient.

The Tilt version code 01327 allows adjusting the platform from 0 to 10 degrees by means of a single hand control. It allows increasing the level of difficulty for the ambulation of the user within a therapy and rehabilitation programme.

### STORAGE

The following environmental conditions must be ensured when the equipment is to be stored:

- relative humidity 10% / 90 % - temperature -10°C / +50°C

## 2. SPECIAL WARNINGS AND USE RESTRICTIONS

**The appropriateness of the PARALLEL BARS PLUS use must be evaluated by a specialist.**

**The equipment has been designed to perform only the functions described in this manual.**

**The equipment must not be used:**

- if the original product has been modified or tampered with;
- without the necessary adjustments and user-specific setup.
- Never spill liquid of any kind on the equipment.
- Do not operate the release pedal when the patient is on the platform: handrail support will not be guaranteed by the springs alone.
- Do not use the glider if the safety stops have not been fitted to the handrails.
- Do not load the handrails, the platform (where specified) and the glider beyond the allowed safety limit.
- The wooden and plastic components of the equipment can catch fire in contact with naked flames.
- The adjustable or moving parts can cause injury.

## 3. USE

### SETUP:

**01325 – 01326 – 01391 – PARALLEL BARS PLUS 2M - 3M - 2M and CHILDREN'S**

**01327 – PARALLEL BARS PLUS 3M TILT refer to instructions in the attached manual.**

1. Remove the equipment, ramps and hardware bags from the packaging.
2. Put the walking platform on one side.
3. Install the ramps with the hardware provided (Fig. 1).
4. Install the gas springs on the uprights from both sides: tighten the self-locking nut, leaving the spacers free to rotate (Fig. 2).
5. Place the platform in position for use.
6. Install the handrails with the hardware provided: tighten the self-locking nut thus allowing smooth height adjustment (Fig.3).



Your strong back partner....

Chiroform Ltd  
Mariendalsvej 22 • 8800 Viborg  
Tel. +4586613611  
E-mail: chiroform@chiroform.dk  
www.chiroform.com

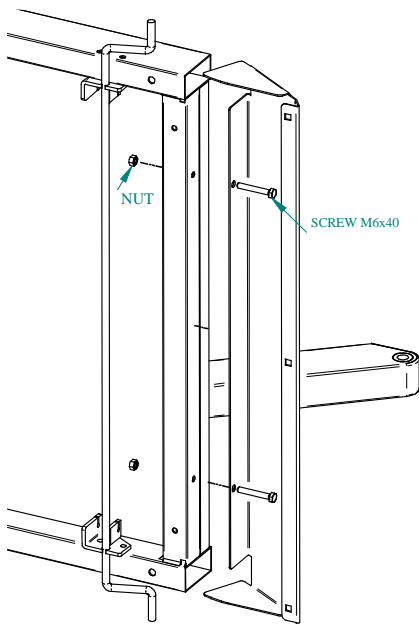

Fig. 1

RAMP MOUNTING DIAGRAM

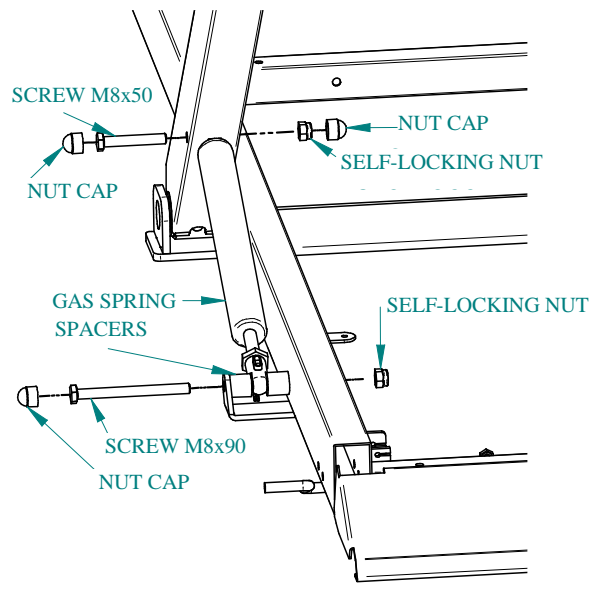

Fig. 2

HANDRAIL GAS SPRING MOUNTING DIAGRAM

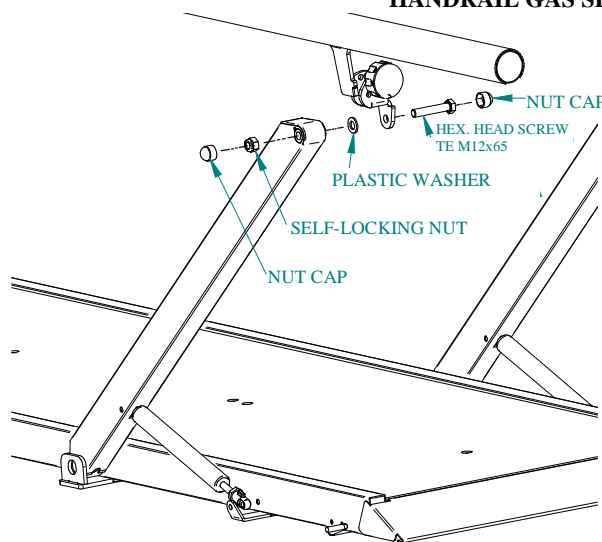

Fig. 3

HANDRAIL MOUNTING DIAGRAM

**HANDRAIL HEIGHT ADJUSTMENT:**

1. Grasp the handrails, release the position by pressing the pedal control (same effect achieved on right and left pedal)
2. Bring the handrails to the desired height and release the pedal to maintain the position.

**⚠ WARNING:**

During the handrail height adjustment, the springs alone will not ensure that the patient is secure on the platform.

**HANDRAIL WIDTH ADJUSTMENT**

1. Unscrew one of the two knobs, on each handrail, until removing the pin from the three-hole blade.
2. Loosen the other knob (on the same handrail) and pull the handgrip to remove the pin from the three-hole blade; at this stage, while carrying out this operation with one hand, use the other hand to grab the handrail, which will now be free to move and can therefore be adjusted in width, by inserting the pin into the desired hole.
3. Tighten this knob and then screw back and tighten the other one.
4. The handrails, when tightened to the central hole, allow using the glider, code 01380



TIGHT KNOB



LOOSE KNOB

## ACCESSORIES:

### 01380 – PARALLEL BAR GLIDER

The 01380 parallel bar glider offers effective support in the rehabilitation of insecure patients or patients who need to limit load on the lower limbs.

Mounting and adjustments:

1. Insert the handrail ends into the four safety stops and lock with the locking pin provided.
2. Adjust the handrail width with respect to the central hole.
3. Adjust the handrail height with reference to the height of the glider bearing surface suitable for the individual patient.
4. Mount the glider and adapt the inclination and depth of the handgrips to the patient's grasp.

#### WARNING:

- **The glider is for use only with the CHINESPORT parallel bar systems specified in this manual.**
- **Do not use the glider without the safety stops; check that these stay in position during use.**
- **Before using the glider, make sure all of its wheels are in line and in contact with the handrails.**
- **We recommend you to disinfect periodically the leatherette and handgrips so as to use the glider in hygienic conditions.**



The parallel bar glider can be connected to another glider by means of a "linkage bar". The advantage is that the patient will find the second glider preset to resume the exercise in the opposite direction.

### MODULES FOR THERAPY AND REHABILITATION PATHS:

A series of thermoplastic modules and bags containing different materials (see technical sheet) can be used to create walking paths within a specific therapy and rehabilitation programme.

The modules can be combined to create uniform or varied paths both on the parallel bar platform and the floor.

The "obstacle - divider" item code 01330 feature permanent magnets that allow these elements to stick firmly to the platform both when arranged as obstacles (mounting on the metal frame) and as central dividers (mounting on the platform near the strikes)

## 4. MAINTENANCE AND CLEANING

### PERIODIC MAINTENANCE

Inspect the equipment every six months to ensure safe operating conditions, check for mechanical solidity, tightness of screws, adjustment of slide and lock, and the wear of the tread surface.

Check the equipment whenever it has undergone a "rough treatment" (e.g.: fall, liquid spill, etc.) and whenever any doubts arise concerning its safety.



WARNING



Under normal conditions of use both the handrails and the tilt Kit (when installed) must be secured and stable. Otherwise do not use until assistance from technical support is given.

### EXTRAORDINARY MAINTENANCE

Maintenance must be carried out by specialized technicians who are familiar with these instructions.

### CLEANING

The platform can be cleaned with a cloth dampened with water and the detergent commonly used for cleaning floors: dry thoroughly, avoid water stagnation that could damage the platforms. Clean the handrails with mild disinfectants.

## 5. TECHNICAL SHEET

|   | 01325  | 01326       | 01327 | 01391      |
|---|--|-------------|-------|------------|
| Conformity                                  | European Community Directives EEC 93/42, EN12182 |             |       |            |
| Weight (Kg)                                 | 73   | 99          | 106   | 71         |
| Max. Dimensions (cm)                        | 211x104x108                                      | 311x104x108 |       | 211x104x87 |
| Handrail capacity (each) (Kg)               | 135  |             |       |            |
| Inclined platform capacity (Kg)             | -  |             | 150   | -          |
| Handrail height adjustment (cm)             | 74↔101   |             |       | 64↔80      |
| Handrail width adjustment (cm)              | 55↔71  |             |       |            |
| <b>ACCESSORIES</b>                          |  |             |       |            |
| 01380 Parallel bar glider (Capacity 135 Kg) | 70x39xh20cm                                      | O           |       |            |
| 01335 Trolley for portable paths            | 48x27xh100cm                                     | O           |       |            |
| 01379 Set of therapy paths                  |  | O           |       |            |
| 01330 Obstacle -divider                     | 63x7xh13 cm                                      | O           |       |            |
| 02510 Set of bags                           | 22x15cm  | O           |       |            |
| 08585 Sensory bags                          | 22x15cm  | O           |       |            |
| 08586 Rolls and bags                        | 57x28cm  | O           |       |            |
| 08587 Sensory Module                        | 57x28cm  | O           |       |            |
| 08589 Hemispheres                           | 57x28cm  | O           |       |            |
| 08591 Concave - convex                      | 57x28cm  | O           |       |            |

## 6. MAIN DIMENSIONS

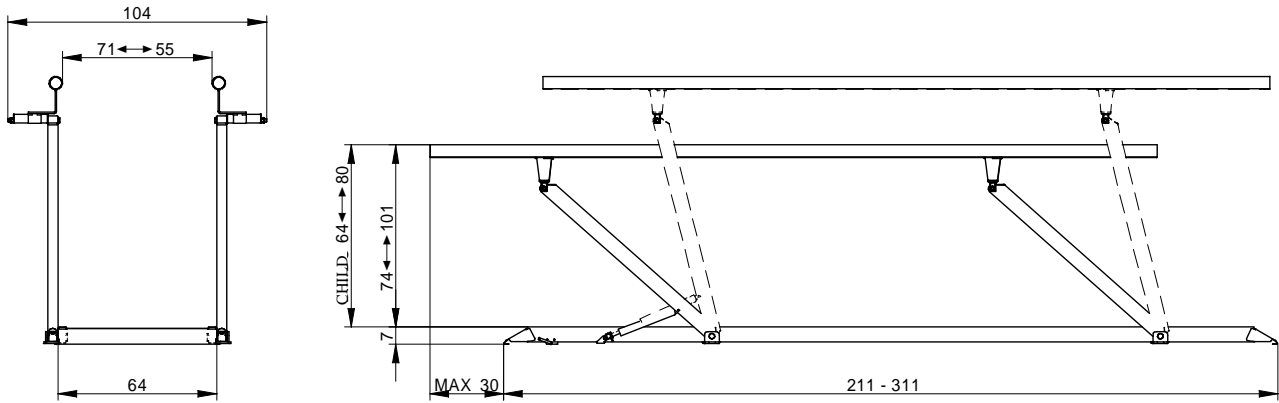

## 7. DECLARATION OF CONFORMITY

Item Code – Product Name

01325 PARALLEL BARS PLUS 2M - 01326 PARALLEL BARS PLUS 3M  
01327 PARALLEL BARS TILT 3M - 01391 CHILDREN'S PARALLEL BARS PLUS 2M  
01380 PARALLEL BAR GLIDER - 01335 CART FOR PORTABLE PATHS  
01379 SET OF THERAPY PATHS - 01330 OBSTACLE-DIVIDER  
08585 SENSORY BAGS - 08586 ROLLS AND BAGS - 08587 SENSORY MODULES  
08589 HEMISPHERES - 08591 CONCAVE-CONVEX - 02510 SET OF BAGS  
Rehabilitation Equipment for use in Ambulation Training.

Class

( Art. 8 of Italian Law Decree No. 46 of 24/03/1997)

The "Standard" Remedial Parallel Bars are made in conformity with European Union Directive 93/42

**I**

CHINESPORT S.p.A.  
(Legal Rep.)

## 8. WARRANTY

### GENERAL AFTER-SALES SERVICE TERMS AND CONDITIONS FOR CHINESPORT PRODUCTS

The warranty is valid 24 months from the date of delivery.

The warranty does not cover consumable items, rechargeable batteries, and generally all the material subject to wear, breakdowns caused by knocks, falls, misuse or improper use, accidental events and transport damage. This warranty will be automatically invalidated if the equipment is tampered with.

Repairs on the equipment will be carried out in relation to the breakdown stated.

An estimate must be specifically requested.

Payment is cash on delivery, unless other agreements are made.

Any dispute will be dealt with solely by the Court of UDINE.

### WARRANTY REPAIRS

Repairs under warranty must be specifically requested.

Repairs under warranty shall be carried out at our workshop and upon authorization.

The return shipment for products sent in their original packaging will be made free of carriage charges.

A fiscal document is required to make a warranty claim; the purchase date indicated must fall within the warranty time period (bill of sale, purchase invoice or cash receipt). If the product is found to be in good working order without defect, the fault-finding service shall be charged to the customer.

### OUT-OF-WARRANTY REPAIRS

For out-of-warranty repairs carried out at our workshops upon authorization, transportation charges shall be paid by the customer.

The warranty on the parts, replaced during the repair operations, is 12 months from the moment the equipment is collected.

If the product is found to be in good working order without defect, the fault-finding service shall be charged to the customer.

### REPAIRS MADE AT HOME

In the event repairs are made at the customer's home, a written request is required indicating the complete details of the person making the request, the type of machine and the breakdown.

The cost per kilometre for on-site technician visits will be agreed upon in relation to the urgency of the customer.

In the event the machine is under warranty, the customer will have to pay only the expenses incurred for the technician to reach the customer's house.

Time is calculated from the moment the technician leaves our workshop until he/she returns. The time of his/her return will be estimated based on the time required to get there.

### SALE OF SPARE PARTS AND CONSUMABLE ITEMS

The orders must be in writing and specify the customer, the item and the shipping method as well as the precise fiscal data of the customer.

The order processing time can vary depending on the availability of the material.

The return of spare parts will not be accepted.

Payment shall be cash on delivery, unless other agreements are made.



Your strong back partner....