

EMC Test Report

Client Name : Guangzhou HuiKang Electronic Technology Co., Ltd
Address : No. 6, Dongnan Road, Milong village, Taihe Town, Baiyun District, Guangzhou, China
Product Name : Far infrared sauna blanket
Date : Apr. 02, 2021

Shenzhen Anbotek Compliance Laboratory Limited



Contents

1. General Information.....	5
1.1. Client Information.....	5
1.2. Description of Device (EUT).....	5
1.3. Auxiliary Equipment Used During Test.....	5
1.4. Description of Test Mode.....	6
1.5. Test Summary.....	6
1.6. Test Equipment List.....	7
1.7. Description of Test Facility.....	8
1.8. EMS Performance Criteria.....	9
2. Power Line Conducted Emission Test.....	10
2.1. Test Standard and Limit.....	10
2.2. Test Setup.....	10
2.3. EUT Configuration on Measurement.....	10
2.4. Operating Condition of EUT.....	10
2.5. Test Procedure.....	11
2.6. Test Results.....	11
3. Disturbance Power Test.....	14
3.1. Test Standard and Limit.....	14
3.2. Test Setup.....	14
3.3. EUT Configuration on Measurement.....	14
3.4. Operating Condition of EUT.....	14
3.5. Test Procedure.....	15
3.6. Test Results.....	15
4. Harmonic Current Emission Test.....	17
4.1. Test Standard.....	17
4.2. Test Setup.....	17
4.3. Operating Condition of EUT.....	17
4.4. Test Results.....	17
5. Voltage Fluctuations & Flicker Test.....	20
5.1. Test Standard.....	20
5.2. Test Setup.....	20
5.3. Operating Condition of EUT.....	20
5.4. Test Results.....	20
6. Electrostatic Discharge Immunity Test.....	22
6.1. Test Standard and Level.....	22
6.2. Test Setup.....	22
6.3. EUT Configuration on Measurement.....	22
6.4. Operating Condition of EUT.....	22
6.5. Test Procedure.....	23



6.6. Test Results.....	23
7. Electrical Fast Transient/Burst Immunity Test.....	25
7.1. Test Standard and Level.....	25
7.2. Test Setup.....	25
7.3. EUT Configuration on Measurement.....	25
7.4. Operating Condition of EUT.....	25
7.5. Test Procedure.....	26
7.6. Test Results.....	26
8. Surge Immunity Test.....	28
8.1. Test Standard and Level.....	28
8.2. Test Setup.....	28
8.3. EUT Configuration on Measurement.....	28
8.4. Operating Condition of EUT.....	28
8.5. Test Procedure.....	29
8.6. Test Results.....	29
9. Injected Currents Susceptibility Test.....	31
9.1. Test Standard and Level.....	31
9.2. Test Setup.....	31
9.3. EUT Configuration.....	31
9.4. Operating Condition of EUT.....	31
9.5. Test Procedure.....	32
9.6. Test Results.....	32
10. Voltage Dips And Interruptions Test.....	34
10.1. Test Standard and Level.....	34
10.2. Test Setup.....	34
10.3. EUT Configuration on Measurement.....	34
10.4. Operating Condition of EUT.....	35
10.5. Test Procedure.....	35
10.6. Test Results.....	35
APPENDIX I -- TEST SETUP PHOTOGRAPH.....	37
APPENDIX II -- PHOTOGRAPH.....	41

TEST REPORT

Applicant : Guangzhou HuiKang Electronic Technology Co., Ltd
Manufacturer : Guangzhou HuiKang Electronic Technology Co., Ltd
Product Name : Far infrared sauna blanket
Model No. : S-102, S-102A, S-102B
Trade Mark : Huikang
Rating(s) : AC220-230V, 50Hz, 500W

Test Standard(s) : **EN 55014-1: 2017;**
EN IEC 61000-3-2: 2019;
EN 61000-3-3: 2013+A1:2019;
EN 55014-2: 2015
(IEC 61000-4-2; IEC 61000-4-4;
IEC 61000-4-5; IEC 61000-4-6; IEC 61000-4-11)

The device described above is tested by Shenzhen Anbotek Compliance Laboratory Limited To determine the maximum emission levels emanating from the device and the severe levels of the device can endure and its performance criterion. This report shows the EUT to be technically compliant with the EN 55014-1, EN IEC 61000-3-2, EN 61000-3-3 and EN 55014-2 requirements. The test results are contained in this report and Shenzhen Anbotek Compliance Laboratory Limited Is assumed full responsibility for the accuracy and completeness of these tests.

This report applies to above tested sample only and shall not be reproduced in part without written approval of Shenzhen Anbotek Compliance Laboratory Limited

Date of Receipt: Mar. 17, 2021

Date of Test: Mar. 17 ~ 26, 2021

Prepared By:

Yee Huang

(Engineer / Yee Huang)

Reviewer:

Bibo Zhang

(Supervisor / Bibo Zhang)

Approved & Authorized Signer:

KingKong Jin

(Manager / KingKong Jin)

1. General Information

1.1. Client Information

Applicant	:	Guangzhou HuiKang Electronic Technology Co., Ltd
Address	:	No. 6, Dongnan Road, Milong village, Taihe Town, Baiyun District, Guangzhou, China
Manufacturer	:	Guangzhou HuiKang Electronic Technology Co., Ltd
Address	:	No. 6, Dongnan Road, Milong village, Taihe Town, Baiyun District, Guangzhou, China
Factory	:	Guangzhou HuiKang Electronic Technology Co., Ltd
Address	:	No. 6, Dongnan Road, Milong village, Taihe Town, Baiyun District, Guangzhou, China

1.2. Description of Device (EUT)

Product Name	:	Far infrared sauna blanket	
Model No.	:	S-102, S-102A, S-102B (Note: All samples are the same except the model number & appearance, so we prepare "S-102" for test only.)	
Trade Mark	:	Huikang	
Test Power Supply	:	AC 230V, 50Hz	
Test Sample No.	:	1-1-1	
Product Description	:	Adapter:	N/A
Remark: (1) For a more detailed features description, please refer to the manufacturer's specifications or the User's Manual.			

1.3. Auxiliary Equipment Used During Test

N/A	
-----	--

1.4. Description of Test Mode

Pretest Mode	Description
Mode 1	Working

For Mode 1 Block Diagram of Test Setup



1.5. Test Summary

Test Items	Test Mode	Status
Power Line Conducted Emission Test (150kHz To 30MHz)	Mode 1	P
Disturbance Power Test (30MHz To 300MHz)	Mode 1	P
Radiated Emission Test (30MHz To 1000MHz)	/	N
Harmonic Current Test	Mode 1	P
Voltage Fluctuations and Flicker Test	Mode 1	P
Electrostatic Discharge immunity Test	Mode 1	P
RF Field Strength susceptibility Test	/	N
Electrical Fast Transient/Burst Immunity Test	Mode 1	P
Surge Immunity Test	Mode 1	P
Injected Currents Susceptibility Test	Mode 1	P
Voltage Dips and Interruptions Test	Mode 1	P
P) Indicates "PASS".		
N) Indicates "Not applicable".		

Note: The EUT is Category II Products, No Requirement for R/S Testing

1.6. Test Equipment List

Conducted Emission Measurement

Item	Equipment	Manufacturer	Model No.	Serial No.	Last Cal.	Cal. Interval
1.	L.I.S.N. Artificial Mains Network	Rohde & Schwarz	ENV216	100055	Oct. 26, 2020	1 Year
2.	L.I.S.N. Artificial Mains Network	Schwarzbeck	NSLK 8127	8127386	Oct. 26, 2020	1 Year
3.	EMI Test Receiver	Rohde & Schwarz	ESCI	100627	Oct. 26, 2020	1 Year
4.	RF Switching Unit	Compliance Direction	RSU-M2	38303	Oct. 26, 2020	1 Year
5.	Software Name EZ-EMC	Ferrari Technology	ANB-03A	N/A	N/A	N/A

Power Clamp Measurement

Item	Equipment	Manufacturer	Model No.	Serial No.	Last Cal.	Cal. Interval
1.	Absorbing Clamp	FCC	F-201-23MM	08166	Nov. 02, 2020	1 Year
2.	EMI Test Receiver	Rohde & Schwarz	ESCI	100627	Oct. 26, 2020	1 Year
3.	RF Switching Unit	Compliance Direction	RSU-M2	38303	Oct. 26, 2020	1 Year
4.	Software Name EZ-EMC	Ferrari Technology	ANB-03A	N/A	N/A	N/A

Harmonic and Flicker Measurement

Item	Equipment	Manufacturer	Model No.	Serial No.	Last Cal.	Cal. Interval
1.	Programmable AC Power source	IVYTECH	APS-5005A	632734	Oct. 26, 2020	1 Year
2.	Harmonic and Flicker Analyzer	EMC-PARTNER	HMONICS 1000-1P	164	Oct. 26, 2020	1 Year
3.	Harmonics-1000	N/A	Ed.3.0+4.0	N.A	N/A	N/A

Electrostatic Discharge Measurement

Item	Equipment	Manufacturer	Model No.	Serial No.	Last Cal.	Cal. Interval
1.	ESD Simulators	3Ctest	EDS-30T	ES0131505	Oct. 28, 2020	1 Year

Electrical Fast Transient/Burst Immunity Measurement

Item	Equipment	Manufacturer	Model No.	Serial No.	Last Cal.	Cal. Interval
1.1	EFT Burst Simulator	PRIMA	EFT61004B	PR10114282	Oct. 26, 2020	1 Year
1.2	EFT-Clamp	PRIMA	EFT-Clamp	/	Oct. 26, 2020	1 Year
2.1	EFT Burst Simulator	TESEQ	NSG 3060	1480	Oct. 26, 2020	1 Year
2.2	CDN	TESEQ	CDN 3061	1408	Oct. 26, 2020	1 Year

Surge Measurement

Item	Equipment	Manufacturer	Model No.	Serial No.	Last Cal.	Cal. Interval
1.	Surge Generator	TESEQ	NSG 3060	1480	Oct. 26, 2020	1 Year
2.	CDN	TESEQ	CDN 3061	1408	Oct. 26, 2020	1 Year
3.	Telecom port surge generator	PMI	TW101	190411	Apr.17,2020	1 Year

Injected Currents Susceptibility Measurement

Item	Equipment	Manufacturer	Model No.	Serial No.	Last Cal.	Cal. Interval
1.	C/S Conducted Immunity Test System	FRANKONIA	CIT-10	126A1196/2012	Oct. 26, 2020	1 Year
2.	CDN	FRANKONIA	CDN - M2+ M3	A2210178/2012	Oct. 26, 2020	1 Year
3.	6dB Attenuator	FRANKONIA	DAM 26W	1172202	Oct. 26, 2020	1 Year
4.	CIT-10	FRANKONIA	Version1.1.7	N/A	N.A	N/A
5.	EM-Clamp	FRANKONIA	EMCL-20	18101728-0103	May.20,2020	1 Year

Voltage Dips and Interruptions Measurement

Item	Equipment	Manufacturer	Model No.	Serial No.	Last Cal.	Cal. Interval
1.	CYCLE SAG Simulator	PRIMA	DRP61011A G	PR12046234	Oct. 26, 2020	1 Year

1.7. Description of Test Facility

The test facility is recognized, certified, or accredited by the following organizations:

FCC-Registration No.: 184111

Shenzhen Anbotek Compliance Laboratory Limited, EMC Laboratory has been registered and fully described in a report filed with the (FCC) Federal Communications Commission. The acceptance letter from the FCC is maintained in our files. Registration No. 184111, September 30, 2020.

ISED-Registration No.: 8058A

Shenzhen Anbotek Compliance Laboratory Limited, EMC Laboratory has been registered and fully described in a report filed with the (ISED) Innovation, Science and Economic Development Canada. The acceptance letter from the ISED is maintained in our files. Registration 8058A, September 30, 2020.

Test Location

Shenzhen Anbotek Compliance Laboratory Limited.

1/F, Building D, Sogood Science and Technology Park, Sanwei community, Hangcheng Street, Bao'an District, Shenzhen, Guangdong, China.518128

1.8. EMS Performance Criteria

- √ A: Normal performance within the specification limits
- √ B: Temporary degradation or loss of function or performance which is self-recoverable
- √ C: Temporary degradation or loss of function or performance which requires operator intervention or system reset
- √ D: Degradation or loss of function which is not recoverable due to damage of equipment (components) or software, or loss of data

Note: The manufacturer's specification may define effects on the EUT which may be considered insignificant, and therefore acceptable.

This classification may be used as a guide in formulating performance criteria, by committees responsible for generic, product and product-family standards, or as a framework for the agreement on performance criteria between the manufacturer and the purchaser, for example where no suitable generic, product or product-family standard exists.

2. Power Line Conducted Emission Test

2.1. Test Standard and Limit

Test Standard	EN 55014-1
---------------	------------

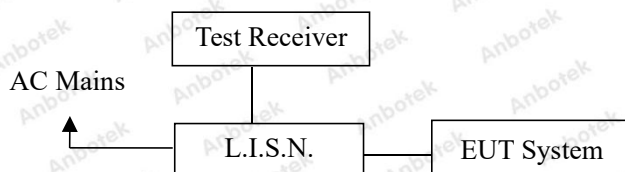
Limits for conducted emissions

Test Limit	Frequency (MHz)	At mains terminals (dB μ V)	
		Quasi-peak Level	Average Level
	0.15 ~ 0.50	66.0 ~ 56.0*	59.0 ~ 46.0*
	0.50 ~ 5.00	56.0	46.0
	5.00 ~ 30.00	60.0	50.0

Remark: (1) The lower limit shall apply at the transition frequencies.

(2) The limit decreases linearly with the logarithm of the frequency in the range 0.15MHz to 0.50MHz.

2.2. Test Setup



2.3. EUT Configuration on Measurement

The following equipments are installed on Conducted Emission Measurement to meet EN 55014-1 requirements and operating in a manner which tends to maximize its emission characteristics in a normal application.

2.4. Operating Condition of EUT

2.4.1. Setup the EUT as shown in Section 2.2.

2.4.2. Turn on the power of all equipments.

2.4.3. Let the EUT work in test mode and measure it.

2.5. Test Procedure

The EUT is put on the plane 0.8 m high above the ground by insulating support and connected to the AC mains through Line Impedance Stability Network(L.I.S.N). This provided a 50ohm coupling impedance for the tested equipments. Both sides of AC line are investigated to find out the maximum conducted emission according to the EN 55014-1 regulations during conducted emission measurement.

The bandwidth of the field strength meter (R&S Test Receiver ESCI) is set at 9kHz in 150kHz~30MHz.

The frequency range from 150 kHz to 30MHz is investigated for AC mains.

All the test results are listed in Section 2.6.

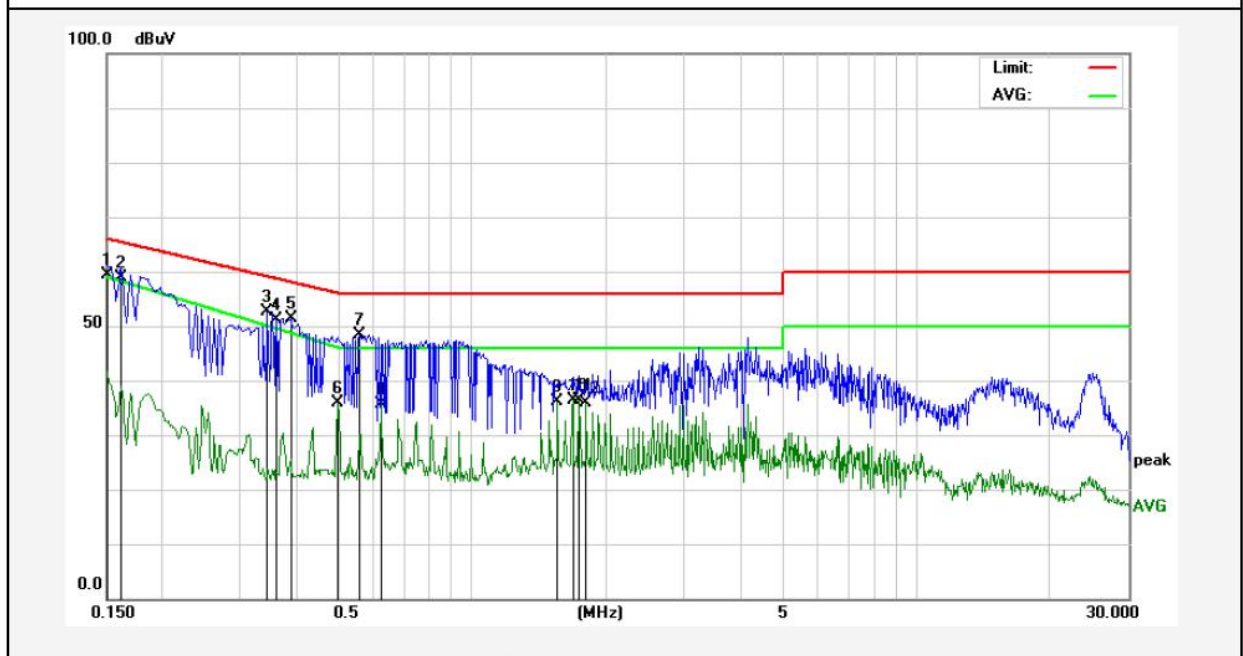
2.6. Test Results

PASS

The test curves are shown in the following pages.

Conducted Emission Test Data

Test Site: 1# Shielded Room
 Test Specification: AC 230V, 50Hz
 Comment: Live Line
 Temp.: 20.9°C Hum.: 45%

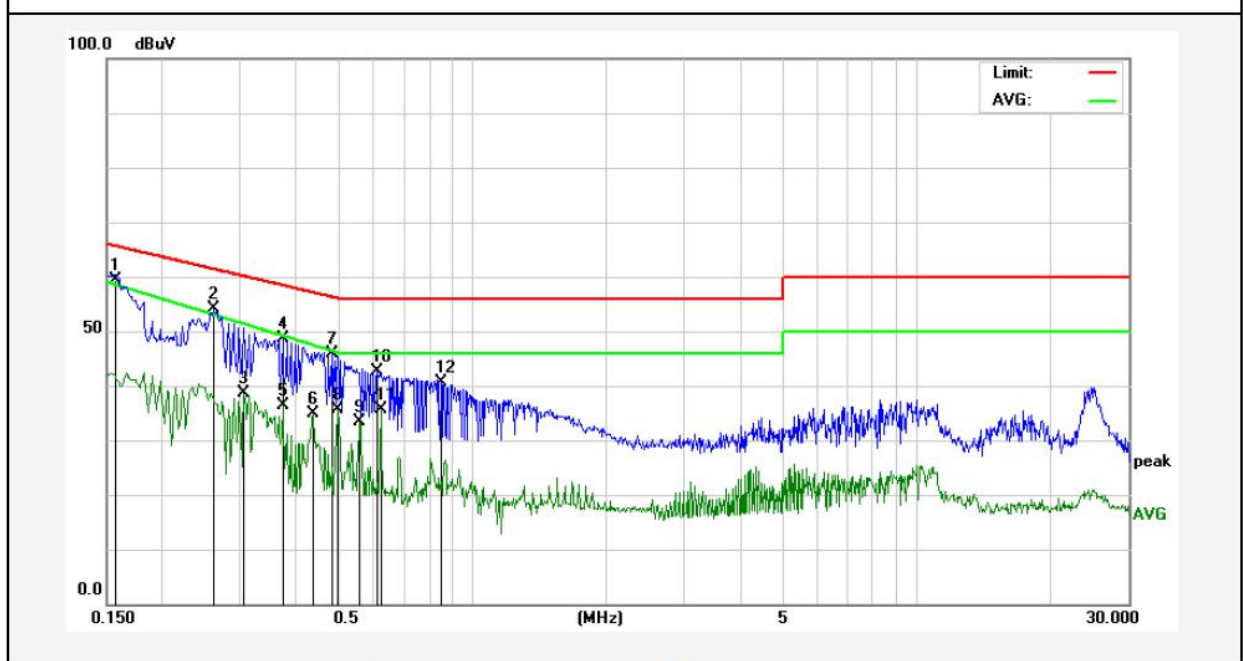


No.	Freq. (MHz)	Reading (dBuV)	Factor (dB)	Result (dBuV)	Limit (dBuV)	Over Limit (dB)	Detector	Remark
1	0.1499	39.37	19.90	59.27	66.00	-6.73	QP	
2	0.1620	39.07	19.90	58.97	65.36	-6.39	QP	
3	0.3457	32.67	19.91	52.58	59.06	-6.48	QP	
4	0.3618	31.30	19.92	51.22	58.69	-7.47	QP	
5	0.3899	31.34	19.93	51.27	58.06	-6.79	QP	
6	0.4979	15.80	19.98	35.78	46.05	-10.27	AVG	
7	0.5580	28.49	20.00	48.49	56.00	-7.51	QP	
8	0.6219	15.60	20.02	35.62	46.00	-10.38	AVG	
9	1.5540	15.88	20.13	36.01	46.00	-9.99	AVG	
10	1.6817	16.31	20.13	36.44	46.00	-9.56	AVG	
11	1.7419	16.28	20.13	36.41	46.00	-9.59	AVG	
12	1.8060	15.66	20.14	35.80	46.00	-10.20	AVG	

Note: **Result=Reading+Factor** **Over Limit=Result-Limit**

Conducted Emission Test Data

Test Site: 1# Shielded Room
 Test Specification: AC 230V, 50Hz
 Comment: Neutral Line
 Temp.: 20.9°C Hum.: 45%



No.	Freq. (MHz)	Reading (dBuV)	Factor (dB)	Result (dBuV)	Limit (dBuV)	Over Limit (dB)	Detector	Remark
1	0.1580	39.46	19.90	59.36	65.56	-6.20	QP	
2	0.2601	34.14	19.89	54.03	61.43	-7.40	QP	
3	0.3059	18.67	19.89	38.56	51.30	-12.74	AVG	
4	0.3738	28.64	19.92	48.56	58.41	-9.85	QP	
5	0.3738	16.36	19.92	36.28	49.14	-12.86	AVG	
6	0.4380	14.83	19.95	34.78	47.43	-12.65	AVG	
7	0.4819	25.99	19.97	45.96	56.31	-10.35	QP	
8	0.4979	15.62	19.98	35.60	46.05	-10.45	AVG	
9	0.5580	13.26	20.00	33.26	46.00	-12.74	AVG	
10	0.6099	22.67	20.01	42.68	56.00	-13.32	QP	
11	0.6219	15.68	20.02	35.70	46.00	-10.30	AVG	
12	0.8499	20.59	20.08	40.67	56.00	-15.33	QP	

Note: Result=Reading+Factor Over Limit=Result-Limit

3. Disturbance Power Test

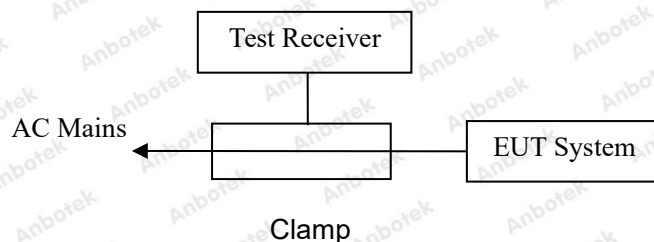
3.1. Test Standard and Limit

Test Standard	EN 55014-1
---------------	------------

Disturbance Power Test Limit

Test Limit	Frequency (MHz)	At mains terminals (dB μ V)	
		Quasi-peak Level	Average Level
	30 ~300	45 Increasing Linearly with Frequency to 55	35 Increasing Linearly with Frequency to 45

3.2. Test Setup



3.3. EUT Configuration on Measurement

The EN 55014-1 Regulations test method must be used to find the maximum emission during disturbance power measurement. The configuration of the EUT is the same as used in conducted emission measurement.

3.4. Operating Condition of EUT

- 3.4.1. Setup the EUT as shown in Section 3.2.
- 3.4.2. Turn on the power of all equipments.
- 3.4.3. Let the EUT work in test mode and measure it.

3.5. Test Procedure

The EUT is placed on the ground and away from other metallic surface at least 0.8m. It is connected to the power mains through an extension cord of 6m min. The absorber clamp clamps the cord and moves from the far end to the EUT to measure the disturbing energy emitted from the cord.

The bandwidth of the test receiver(R&S ESCI) is set at 120kHz.

All the test results are listed in Section 3.6.

3.6. Test Results

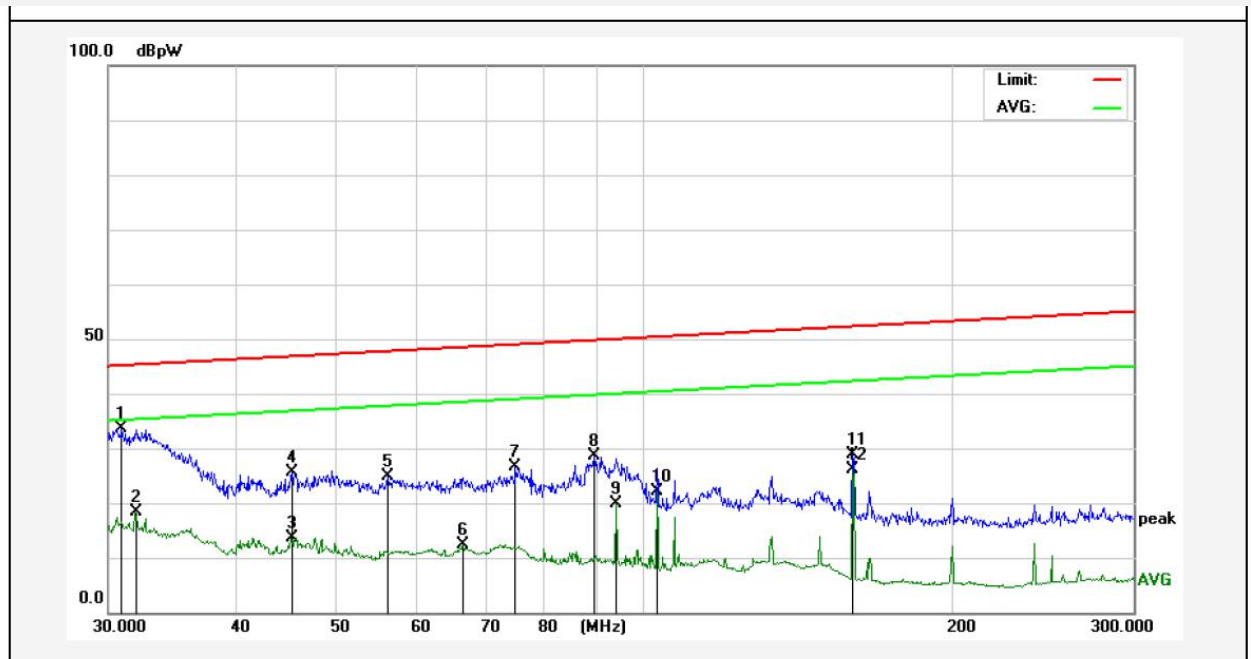
PASS

The frequency spectrum from 30MHz to 300MHz is investigated.

The test curves are shown in the following pages.

Power Clamp Test Data

Test Site: 1# Shielded Room
 Test Specification: AC 230V, 50Hz
 Comment: AC LINE
 Temp.: 20.9°C Hum.: 45%



No.	Freq. (MHz)	Reading (dBpW)	Factor (dB)	Result (dBpW)	Limit (dBpW)	Over Limit (dB)	Detector	Remark
1	30.9199	5.67	27.84	33.51	45.13	-11.62	QP	
2	31.9199	-9.44	27.78	18.34	35.27	-16.93	AVG	
3	45.2799	-12.71	26.28	13.57	36.79	-23.22	AVG	
4	45.3199	-0.57	26.27	25.70	46.79	-21.09	QP	
5	56.1999	-0.63	25.48	24.85	47.73	-22.88	QP	
6	66.5999	-13.57	25.89	12.32	38.46	-26.14	AVG	
7	75.0000	0.38	26.20	26.58	48.98	-22.40	QP	
8	89.5199	4.37	24.24	28.61	49.75	-21.14	QP	
9	93.9200	-4.28	24.20	19.92	39.96	-20.04	AVG	
10	103.0000	-2.51	24.52	22.01	40.36	-18.35	AVG	
11	160.0000	6.14	22.70	28.84	52.27	-23.43	QP	
12	160.0000	3.44	22.70	26.14	42.27	-16.13	AVG	

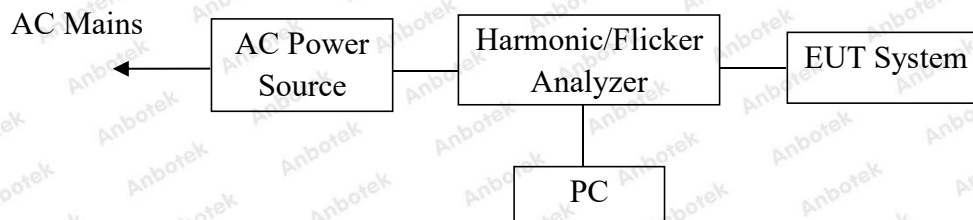
Note: Result=Reading+Factor Over Limit=Result-Limit

4. Harmonic Current Emission Test

4.1. Test Standard

Test Standard	EN IEC 61000-3-2
---------------	------------------

4.2. Test Setup



4.3. Operating Condition of EUT

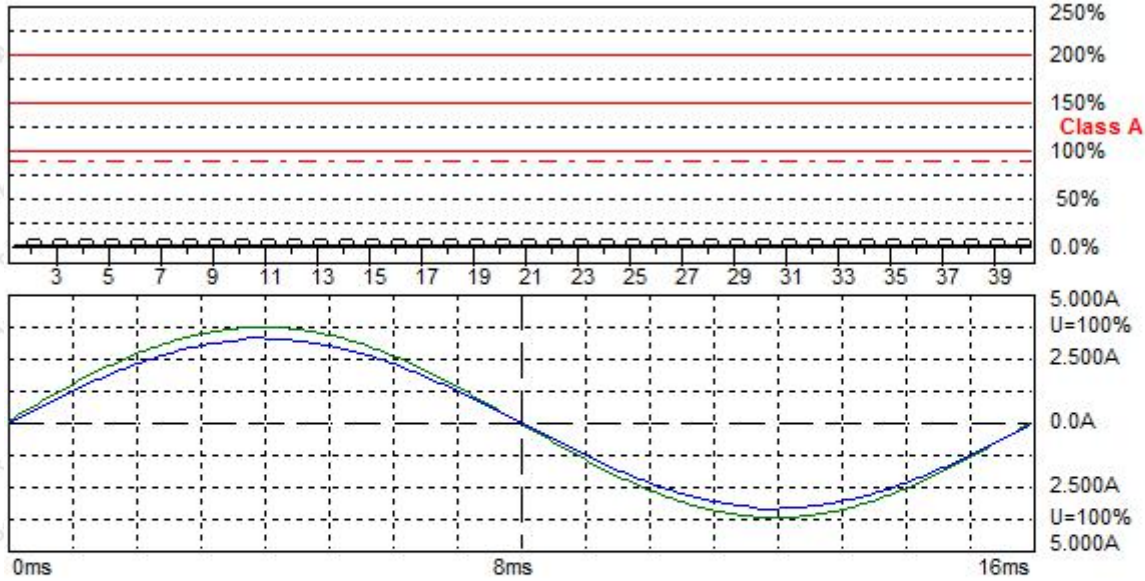
- 4.3.1. Setup the EUT as shown on Section 4.2.
- 4.3.2. Turn on the power of all equipments.
- 4.3.3. After that, let the EUT work in test mode measure it.

4.4. Test Results

PASS

The test curves are shown in the following pages.

Harmonic Current Test Result Summary (Run time)



Harmonic Emission - IEC 61000-3-2 , EN 61000-3-2 , (EN60555-2)

Urms =	229.3 V	P =	533.9 W	THC =	0.017 A	Range:	5 A
Irms =	2.329 A	pf =	1.000			V-nom:	230 V

Test aborted, Result: PASSED

HAR-1000 EMC-Partner

Full Bar : Actual Values
Empty Bar : Maximum Values
Blue : Current , Green : Voltage , Red : Failed

Harmonic Current Test Result Summary (Run time)

Urms = 229.3V Freq = 59.981 Range: 5 A
 Irms = 2.329A Ipk = 3.416A cf = 1.466
 P = 533.9W S = 534.1VA pf = 1.000
 THDi = 0.80 % THDu = 0.20 % Class A

Test - Time : 3min (100 %)

Test aborted, Result: PASSED

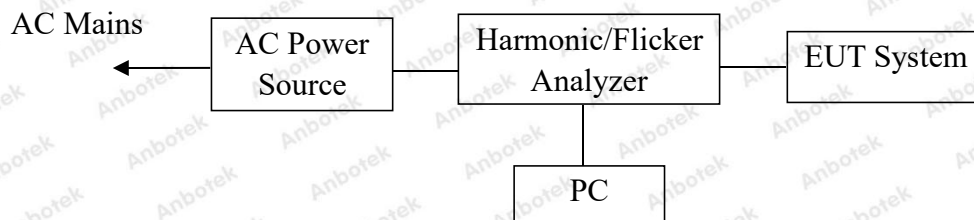
Order	Freq. Status [Hz]	Iavg [A]	Iavg%L [%]	Irms [A]	Irms% [%]	Irms%L [%]	I _{max} [A]	I _{max} %L [%]	Limit [A]
1	60	2.3253		2.3273	99.921		2.3273		
2	120	0.0000	0.0000	0.0027	0.1179	0.2543	0.0031	0.2826	1.0800
3	180	0.0000	0.0000	0.0076	0.3276	0.3317	0.0076	0.3317	2.3000
4	240	0.0000	0.0000	0.0006	0.0262	0.1419	0.0009	0.2129	0.4300
5	300	0.0000	0.0000	0.0034	0.1441	0.2945	0.0034	0.2945	1.1400
6	360	0.0000	0.0000	0.0006	0.0262	0.2035	0.0006	0.2035	0.3000
7	420	0.0000	0.0000	0.0061	0.2621	0.7927	0.0061	0.7927	0.7700
8	480	0.0000	0.0000	0.0003	0.0131	0.1327	0.0003	0.1327	0.2300
9	540	0.0000	0.0000	0.0040	0.1703	0.9918	0.0043	1.0681	0.4000
10	600	0.0000	0.0000	0.0009	0.0393	0.4976	0.0009	0.4976	0.1840
11	660	0.0000	0.0000	0.0052	0.2227	1.5721	0.0052	1.5721	0.3300
12	720	0.0000	0.0000	0.0003	0.0131	0.1990	0.0003	0.1990	0.1533
13	780	0.0000	0.0000	0.0040	0.1703	1.8892	0.0040	1.8892	0.2100
14	840	0.0000	0.0000	0.0003	0.0131	0.2322	0.0003	0.2322	0.1314
15	900	0.0000	0.0000	0.0046	0.1965	3.0518	0.0049	3.2552	0.1500
16	960	0.0000	0.0000	0.0003	0.0131	0.2654	0.0003	0.2654	0.1150
17	1020	0.0000	0.0000	0.0037	0.1572	2.7669	0.0037	2.7669	0.1324
18	1080	0.0000	0.0000	0.0003	0.0131	0.2985	0.0003	0.2985	0.1022
19	1140	0.0000	0.0000	0.0040	0.1703	3.3502	0.0043	3.6079	0.1184
20	1200	0.0000	0.0000	0.0003	0.0131	0.3317	0.0003	0.3317	0.0920
21	1260	0.0000	0.0000	0.0031	0.1310	2.8483	0.0034	3.1331	0.1071
22	1320	0.0000	0.0000	0.0003	0.0131	0.3649	0.0003	0.3649	0.0836
23	1380	0.0000	0.0000	0.0034	0.1441	3.4315	0.0037	3.7435	0.0978
24	1440	0.0000	0.0000	0.0003	0.0131	0.3981	0.0003	0.3981	0.0767
25	1500	0.0000	0.0000	0.0027	0.1179	3.0518	0.0027	3.0518	0.0900
26	1560	0.0000	0.0000	0.0003	0.0131	0.4312	0.0003	0.4312	0.0708
27	1620	0.0000	0.0000	0.0027	0.1179	3.2959	0.0027	3.2959	0.0833
28	1680	0.0000	0.0000	0.0003	0.0131	0.4644	0.0003	0.4644	0.0657
29	1740	0.0000	0.0000	0.0024	0.1048	3.1467	0.0024	3.1467	0.0776
30	1800	0.0000	0.0000	0.0000	0.0000	0.0000	0.0003	0.4976	0.0613
31	1860	0.0000	0.0000	0.0021	0.0917	2.9433	0.0021	2.9433	0.0726
32	1920	0.0000	0.0000	0.0003	0.0131	0.5307	0.0003	0.5307	0.0575
33	1980	0.0000	0.0000	0.0021	0.0917	3.1331	0.0021	3.1331	0.0682
34	2040	0.0000	0.0000	0.0000	0.0000	0.0000	0.0003	0.5639	0.0541
35	2100	0.0000	0.0000	0.0015	0.0655	2.3736	0.0015	2.3736	0.0643
36	2160	0.0000	0.0000	0.0003	0.0131	0.5971	0.0003	0.5971	0.0511
37	2220	0.0000	0.0000	0.0018	0.0786	3.0111	0.0018	3.0111	0.0608
38	2280	0.0000	0.0000	0.0000	0.0000	0.0000	0.0003	0.6303	0.0484
39	2340	0.0000	0.0000	0.0009	0.0393	1.5869	0.0009	1.5869	0.0577
40	2400	0.0000	0.0000	0.0003	0.0131	0.6634	0.0003	0.6634	0.0460

5. Voltage Fluctuations & Flicker Test

5.1. Test Standard

Test Standard	EN 61000-3-3
---------------	--------------

5.2. Test Setup



5.3. Operating Condition of EUT

5.3.1. Setup the EUT as shown on Section 5.2.

5.3.2. Turn on the power of all equipments.

5.3.3. After that, let the EUT work in test mode measure it.

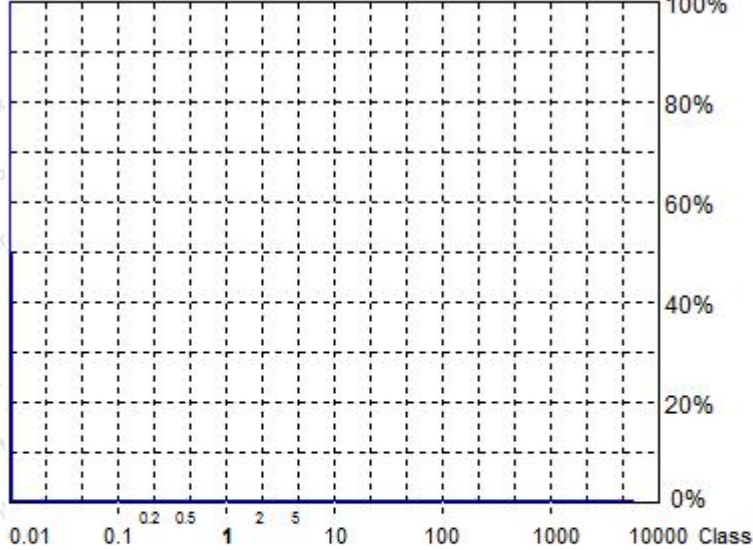
5.4. Test Results

PASS

The test curves are shown in the following pages.

Flicker Test Summary per EN/IEC61000-3-3 (Run time)

Flicker Emission IEC 61000-4-15 for 120V/60Hz



Actual Flicker (Fli):	0.00
Short-term Flicker (Pst):	0.07
Limit (Pst):	1.00
Long-term Flicker (Plt):	0.00
Limit (Plt):	0.65
Maximum Relative Volt. Change (dmax):	0.00%
Limit (dmax):	4.00%
Relative Steady-state Voltage Change (dc):	0.01%
Limit (dc):	3.00%
Tmax 3.00% (dt):	0.00ms
Limit (dt>Lim):	200ms

Flicker Emission - IEC 61000-3-3, EN 61000-3-3

Urms =	228.3 V	P =	531.8 W
Irms =	2.329 A	pf =	1.000

Range:	5 A
V-nom:	230 V

Test aborted, Result: PASSED

HAR-1000 EMC-Partner

Full Bar : Actual Values
Empty Bar : Maximum Values
Circles : Average Values
Blue : Current, Green : Voltage, Red : Failed

Urms =	228.3V	Freq =	60.000	Range:	5 A
Irms =	2.329A	l _{pk} =	3.425A	cf =	1.471
P =	531.8W	S =	531.8VA	pf =	1.000

Test - Time : 10 x 1min = 10min (100 %)

LIN (Line Impedance Network) : L: 0.24ohm +j0.15ohm N: 0.16ohm +j0.10ohm

Limits :	Plt :	0.65	Pst :	1.00
	dmax :	4.00 %	dc :	3.00 %
	dtLim:	3.00 %	dt>Lim:	200ms

Test aborted, Result: PASSED

	dmax	dc	dt>Lim
	[%]	[%]	[ms]
1	0.000	0.000	0.000

6. Electrostatic Discharge Immunity Test

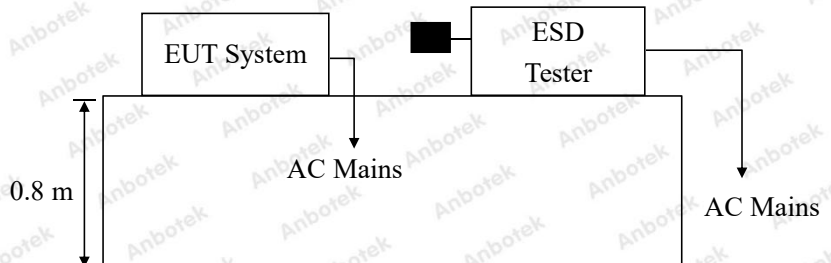
6.1. Test Standard and Level

Test Standard:	EN 55014-2 (IEC 61000-4-2)
Performance Criterion:	B
Severity Level: 3 / Air Discharge: $\pm 8\text{kV}$, Level: 2 / Contact Discharge: $\pm 4\text{kV}$	

Test Level

Level	Test Voltage Contact Discharge (kV)	Test Voltage Air Discharge (kV)
1.	± 2	± 2
2.	± 4	± 4
3.	± 6	± 8
4.	± 8	± 15
X	Special	Special

6.2. Test Setup



6.3. EUT Configuration on Measurement

The following equipments are installed on Electrostatic Discharge immunity Measurement to meet EN 55014-2 requirements and operating in a manner which tends to maximize its emission characteristics in a normal application.

6.4. Operating Condition of EUT

6.4.1. Setup the EUT as shown on Section 6.2.

6.4.2. Turn on the power of all equipments.

6.4.3. After that, let the EUT work in test mode measure it.

6.5. Test Procedure

6.5.1. Air Discharge:

This test is done on a non-conductive surface. The round discharge tip of the discharge electrode shall be approached as fast as possible to touch the EUT. After each discharge, the discharge electrode shall be removed from the EUT. The generator is then re-triggered for a new single discharge and repeated 10 times for each pre-selected test point. This procedure shall be repeated until all the air discharge completed.

6.5.2. Contact Discharge:

All the procedure shall be same as Section 6.5.1 except that the tip of the discharge electrode shall touch the EUT before the discharge switch is operated.

6.5.3. Indirect discharge for horizontal coupling plane

At least 20 single discharges shall be applied to the horizontal coupling plane, at points on each side of the EUT. The discharge electrode positions vertically at a distance of 0.1m from the EUT and with the discharge electrode touching the coupling plane.

6.5.4. Indirect discharge for vertical coupling plane

At least 20 single discharge shall be applied to the center of one vertical edge of the coupling plane. The coupling plane, of dimensions 0.5m × 0.5m, is placed parallel to, and positioned at a distance of 0.1m from the EUT. Discharges shall be applied to the coupling plane, with this plane in sufficient different positions that the four faces of the EUT are completely illuminated.

6.6. Test Results

PASS

Please refer to the following page.

Electrostatic Discharge Test Results

Air discharge :	±8.0kV	Temperature :	23.2°C
Contact discharge :	±4.0kV	Humidity :	50%
Power Supply :	AC 230V, 50Hz	Expert conclusion :	A
Number of discharge :	10	Test Result:	<input checked="" type="checkbox"/> Pass <input type="checkbox"/> Fail
Location		Kind A-Air Discharge C-Contact Discharge	Result
Slot	4 points	A	<input checked="" type="checkbox"/> A <input type="checkbox"/> B <input type="checkbox"/> C <input type="checkbox"/> D
Button	4 points	A	<input checked="" type="checkbox"/> A <input type="checkbox"/> B <input type="checkbox"/> C <input type="checkbox"/> D
Screen	4 points	A	<input checked="" type="checkbox"/> A <input type="checkbox"/> B <input type="checkbox"/> C <input type="checkbox"/> D
HCP	4 points	C	<input checked="" type="checkbox"/> A <input type="checkbox"/> B <input type="checkbox"/> C <input type="checkbox"/> D
VCP of the front	4 points	C	<input checked="" type="checkbox"/> A <input type="checkbox"/> B <input type="checkbox"/> C <input type="checkbox"/> D
VCP of the rear	4 points	C	<input checked="" type="checkbox"/> A <input type="checkbox"/> B <input type="checkbox"/> C <input type="checkbox"/> D
VCP of the left	4 points	C	<input checked="" type="checkbox"/> A <input type="checkbox"/> B <input type="checkbox"/> C <input type="checkbox"/> D
VCP of the right	4 points	C	<input checked="" type="checkbox"/> A <input type="checkbox"/> B <input type="checkbox"/> C <input type="checkbox"/> D
Remark: Discharge should be considered on Contact and Air and Horizontal Coupling Plane (HCP) and Vertical Coupling Plane (VCP).			

7. Electrical Fast Transient/Burst Immunity Test

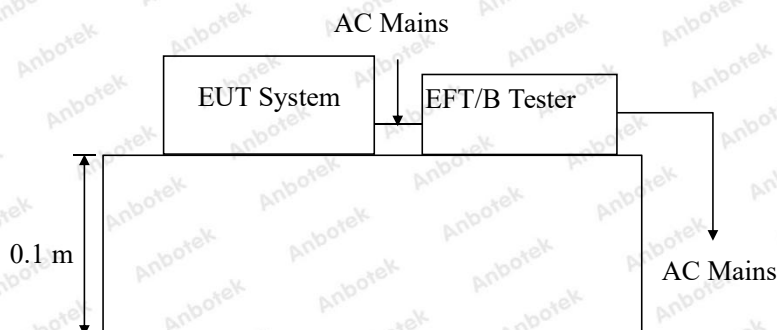
7.1. Test Standard and Level

Test Standard:	EN 55014-2 (IEC 61000-4-4)
Performance criterion:	B
Severity Level 2: 1.00kV	

Test Level

Open Circuit Output Test Voltage $\pm 10\%$		
Level	On Power Supply Lines	On I/O (Input/Output) Signal data and control lines
1.	0.50 kV	0.25 kV
2.	1.00 kV	0.50 kV
3.	2.00 kV	1.00 kV
4.	4.00 kV	2.00 kV
X.	Special	Special

7.2. Test Setup



7.3. EUT Configuration on Measurement

The following equipments are installed on Electrical Fast Transient/Burst Immunity Measurement to meet EN 55014-2 requirements and operating in a manner which tends to maximize its emission characteristics in a normal application.

7.4. Operating Condition of EUT

7.4.1. Setup the EUT as shown in Section 7.2.

7.4.2. Turn on the power of all equipments.

7.4.3. Let the EUT work in test mode and measure it.

7.5. Test Procedure

The EUT is put on the table which is 0.1 meter high above the ground. This reference ground plane shall project beyond the EUT by at least 0.1m on all sides and the minimum distance between EUT and all other conductive structure, except the ground plane beneath the EUT, shall be more than 0.5m.

7.5.1. For input and output AC power ports:

The EUT is connected to the power mains by using a coupling device which couples the EFT interference signal to AC power lines. Both polarities of the test voltage should be applied during compliance test and the duration of the test is 2 mins.

7.5.2. For signal lines and control lines ports:

Select tests based on product characteristics.

7.5.3. For DC output line ports:

Select tests based on product characteristics.

7.6. Test Results

PASS

Please refer to the following page.

Electrical Fast Transient/Burst Test Results

Ambient Condition : 23.3°C / 50% RH		Expert conclusion : A	
Power Supply : AC 230V, 50Hz		Test Result : <input checked="" type="checkbox"/> Pass <input type="checkbox"/> Fail	
Inject Line : AC Mains		Inject Method: Direct	Inject Time(s): 120
Line	Polarity	Test Voltage (kV)	Result
AC Line	±	1.00kV	<input checked="" type="checkbox"/> A <input type="checkbox"/> B <input type="checkbox"/> C <input type="checkbox"/> D
DC Line			
Signal Line			

8. Surge Immunity Test

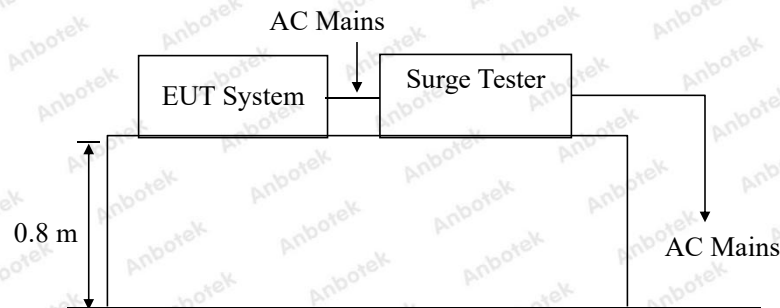
8.1. Test Standard and Level

Test Standard:	EN 55014-2 (IEC 61000-4-5)
Performance criterion:	B
Severity Level 2, Line to Line: 1.0kV; Severity Level 3, Line to Line: 2.0kV	

Test Level

Severity Level	Open-Circuit Test Voltage (kV)
1.	0.5
2.	1.0
3.	2.0
4.	4.0
X.	Special

8.2. Test Setup



8.3. EUT Configuration on Measurement

The following equipments are installed on Surge immunity Measurement to meet EN 55014-2 requirements and operating in a manner which tends to maximize its emission characteristics in a normal application.

8.4. Operating Condition of EUT

- 8.4.1. Setup the EUT as shown in Section 8.2.
- 8.4.2. Turn on the power of all equipments.
- 8.4.3. Let the EUT work in test mode and measure it.

8.5. Test Procedure

8.5.1. Set up the EUT and test generator as shown on Section 10.2.

8.5.2. For line to line coupling mode, provide a 1.0kV 1.2/50us voltage surge (at open-circuit condition) and 8/20us current surge to EUT selected points.

8.5.3. For earth to line coupling mode, provide a 2.0kV 1.2/50us voltage surge (at open-circuit condition) and 8/20us current surge to EUT selected points.

8.5.4. At least 5 positive and 5 negative (polarity) tests with a maximum 1/min repetition rate are conducted during test.

8.5.5. Different phase angles are done individually.

8.5.6. Record the EUT operating situation during compliance test and decide the EUT immunity criterion for above each test.

8.6. Test Results

PASS

Please refer to the following page.

Surge Immunity Test Results

Humidity :	50%		Temperature :	23.2°C	
Power Supply :	AC 230V, 50Hz		Expert conclusion:	A	
Test Result :	<input checked="" type="checkbox"/> Pass <input type="checkbox"/> Fail				
Location	Polarity	Phase Angle	Number of Pulse	Pulse Voltage (kV)	Result
L-N	+	<input type="checkbox"/> 0° <input checked="" type="checkbox"/> 90° <input type="checkbox"/> 180° <input type="checkbox"/> 270°	5	1.0kV	<input checked="" type="checkbox"/> A <input type="checkbox"/> B <input type="checkbox"/> C <input type="checkbox"/> D
L-N	-	<input type="checkbox"/> 0° <input type="checkbox"/> 90° <input type="checkbox"/> 180° <input checked="" type="checkbox"/> 270°	5	1.0kV	<input checked="" type="checkbox"/> A <input type="checkbox"/> B <input type="checkbox"/> C <input type="checkbox"/> D
L-GND	+	<input type="checkbox"/> 0° <input checked="" type="checkbox"/> 90° <input type="checkbox"/> 180° <input type="checkbox"/> 270°	5	2.0kV	<input checked="" type="checkbox"/> A <input type="checkbox"/> B <input type="checkbox"/> C <input type="checkbox"/> D
L-GND	-	<input type="checkbox"/> 0° <input type="checkbox"/> 90° <input type="checkbox"/> 180° <input checked="" type="checkbox"/> 270°	5	2.0kV	<input checked="" type="checkbox"/> A <input type="checkbox"/> B <input type="checkbox"/> C <input type="checkbox"/> D
N-GND	+	<input type="checkbox"/> 0° <input checked="" type="checkbox"/> 90° <input type="checkbox"/> 180° <input type="checkbox"/> 270°	5	2.0kV	<input checked="" type="checkbox"/> A <input type="checkbox"/> B <input type="checkbox"/> C <input type="checkbox"/> D
N-GND	-	<input type="checkbox"/> 0° <input type="checkbox"/> 90° <input type="checkbox"/> 180° <input checked="" type="checkbox"/> 270°	5	2.0kV	<input checked="" type="checkbox"/> A <input type="checkbox"/> B <input type="checkbox"/> C <input type="checkbox"/> D



9. Injected Currents Susceptibility Test

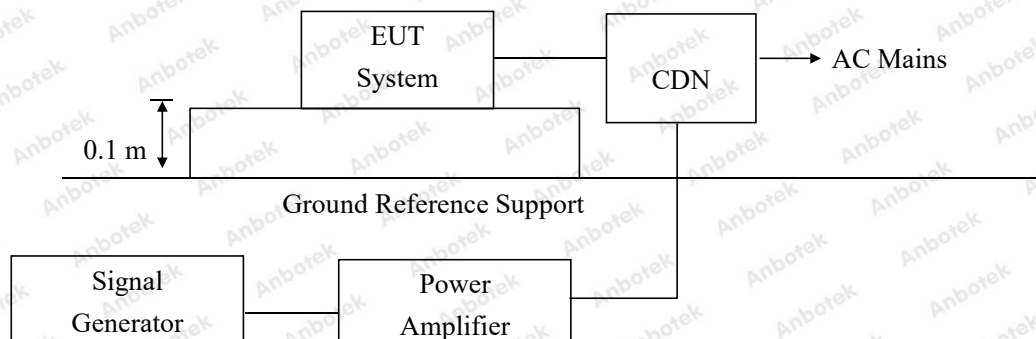
9.1. Test Standard and Level

Test Standard	EN 55014-2 (IEC 61000-4-6)
Performance criterion	A
Severity Level 2: 3V (rms), (0.15MHz ~230MHz)	

Test Level

Level	Field Strength V
1.	1
2.	3
3.	10
X.	Special

9.2. Test Setup



9.3. EUT Configuration

The following equipments are installed on currents susceptibility Measurement to meet EN 55014-2 requirements and operating in a manner which tends to maximize its emission characteristics in a normal application.

9.4. Operating Condition of EUT

9.4.1. Setup the EUT as shown in Section 9.2.

9.4.2. Turn on the power of all equipments.

9.4.3. Let the EUT work in test mode and measure it.

9.5. Test Procedure

- 1) Set up the EUT, CDN and test generators as shown on Section 9.2.
- 2) Let the EUT work in test mode and measure it.
- 3) The EUT are placed on an insulating support 0.1m high above a ground reference plane. CDN (coupling and decoupling device) is placed on the ground plane about 0.3m from EUT. Cables between CDN and EUT are as short as possible, and their height above the ground reference plane shall be between 30 and 50 mm (where possible).
- 4) The disturbance signal described below is injected to EUT through CDN.
- 5) The EUT operates within its operational mode(s) under intended climatic conditions after power on.
- 6) The frequency range is swept from 150KHz to 230MHz using 3V signal level, and with the disturbance signal 80% amplitude modulated with a 1KHz sine wave.
- 7) The rate of sweep shall not exceed $1.5 \cdot 10^{-3}$ decades/s. Where the frequency is swept incrementally, the step size shall not exceed 1% of the start and thereafter 1% of the preceding frequency value.
- 8) Recording the EUT operating situation during compliance testing and decide the EUT immunity criterion.

9.5.1. For signal lines and control lines ports:

Select tests based on product characteristics.

9.5.2. For DC output line ports:

Select tests based on product characteristics.

9.6. Test Results

PASS

Please refer to the following page.

Injected Currents Susceptibility Test Results

Humidity : 50%		Temperature : 23.2°C	
Power Supply : AC 230V, 50Hz		Expert conclusion: A	
Test Result : <input checked="" type="checkbox"/> Pass <input type="checkbox"/> Fail			
Frequency Range (MHz)		Injected Position	
0.15 ~ 230		AC Mains	
Strength (Unmodulated)		Result	
3V		<input checked="" type="checkbox"/> A <input type="checkbox"/> B <input type="checkbox"/> C <input type="checkbox"/> D	
<p>Remark : 1. Modulation Signal:1KHz 80% AM</p>			



10. Voltage Dips And Interruptions Test

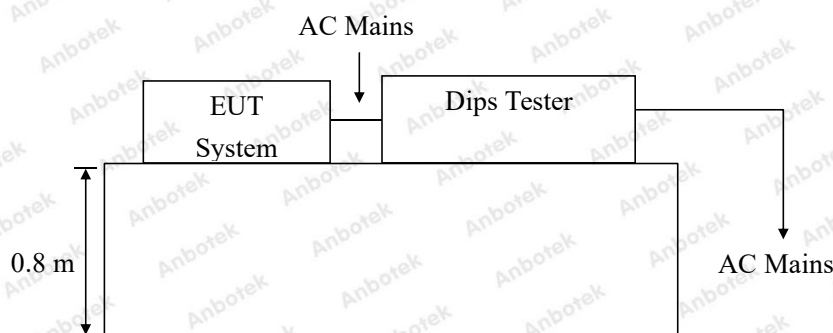
10.1. Test Standard and Level

Test Standard:	EN 55014-2 (IEC 61000-4-11)
Performance Criterion:	C

Test Level

Test Level %UT	Voltage dip and short interruptions %UT	Duration (in period)
0	100	0.5
40	60	1
70	30	5
/	/	10
		25
		50
		*

10.2. Test Setup



10.3. EUT Configuration on Measurement

The following equipments are installed on Voltage dips and interruptions Measurement to meet EN 55014-2 requirements and operating in a manner which tends to maximize its emission characteristics in a normal application.

10.4. Operating Condition of EUT

10.4.1. Setup the EUT as shown in Section 10.2.

10.4.2. Turn on the power of all equipments.

10.4.3. Let the EUT work in test mode and measure it.

10.5. Test Procedure

- 1) Set up the EUT and test generator as shown on Section 10.2.
- 2) The interruptions is introduced at selected phase angles with specified duration.
- 3) Record any degradation of performance.

10.6. Test Results

PASS

Please refer to the following page.

Voltage Dips and Interruptions Test Results

Temperature : 23.2°C		Humidity : 50%	
Power Supply : AC 230V, 50Hz		Expert conclusion : C	
Test Result : <input checked="" type="checkbox"/> Pass <input type="checkbox"/> Fail			
Test Level % UT	Voltage Dips & Short Interruptions % UT	Duration (in periods)	Result
0	100	0.5P	<input type="checkbox"/> A <input type="checkbox"/> B <input checked="" type="checkbox"/> C <input type="checkbox"/> D
40	60	10P	<input type="checkbox"/> A <input type="checkbox"/> B <input checked="" type="checkbox"/> C <input type="checkbox"/> D
70	30	25P	<input type="checkbox"/> A <input type="checkbox"/> B <input checked="" type="checkbox"/> C <input type="checkbox"/> D
Test Level % UT	Voltage Dips & Short Interruptions % UT	Duration (in periods)	Result

APPENDIX I -- TEST SETUP PHOTOGRAPH

Photo of Power Line Conducted Emission Test



Photo of Disturbance Power Test



Photo of Flicker/ Harmonic Test

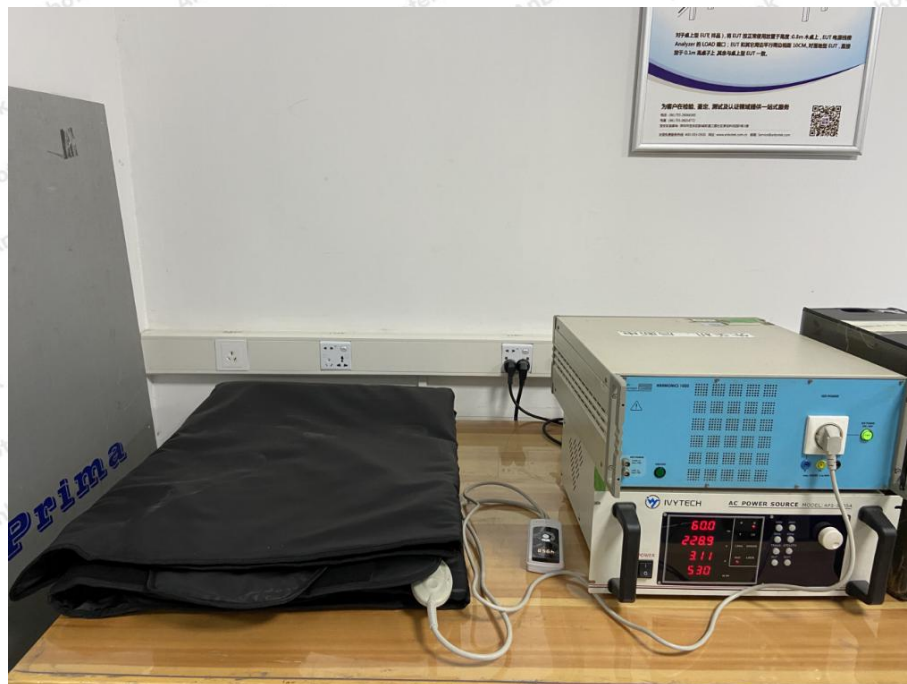


Photo of Electrostatic Discharge Immunity Test

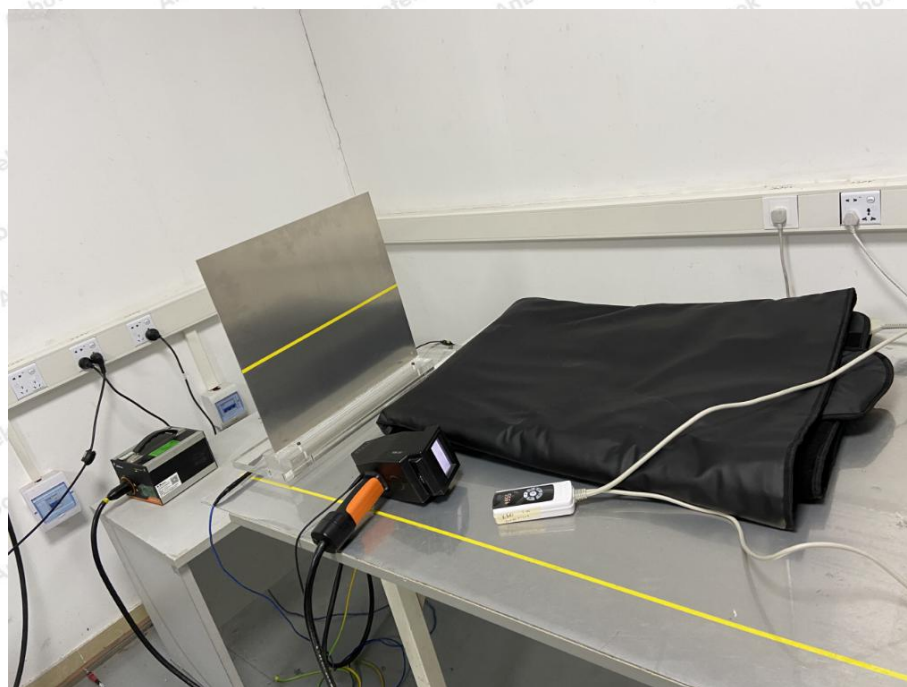


Photo of Electrical Fast Transient/Burst Immunity Test



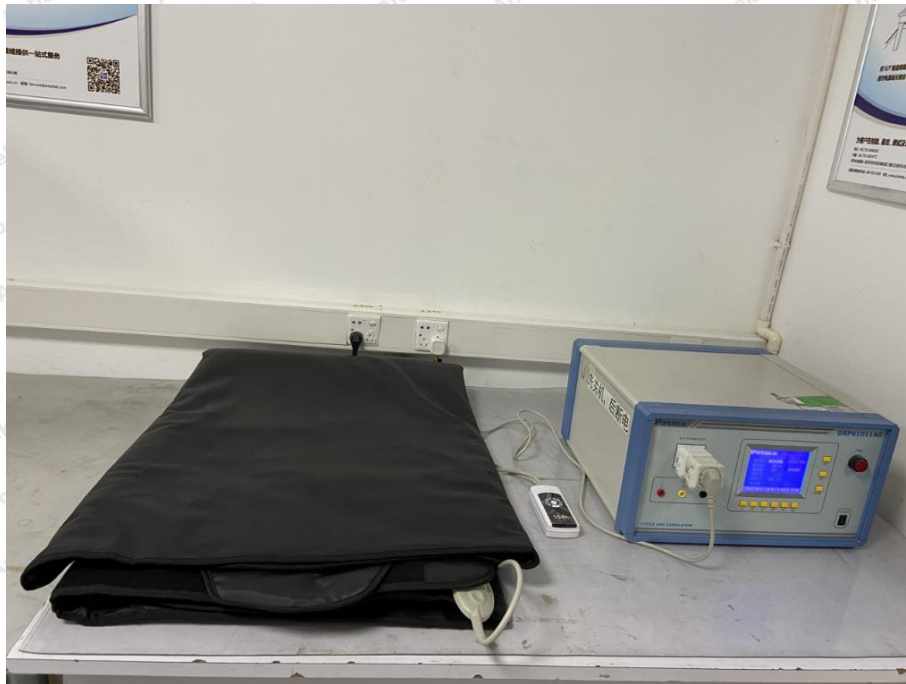
Photo of Surge Immunity Test



Photo of Injected currents susceptibility Test

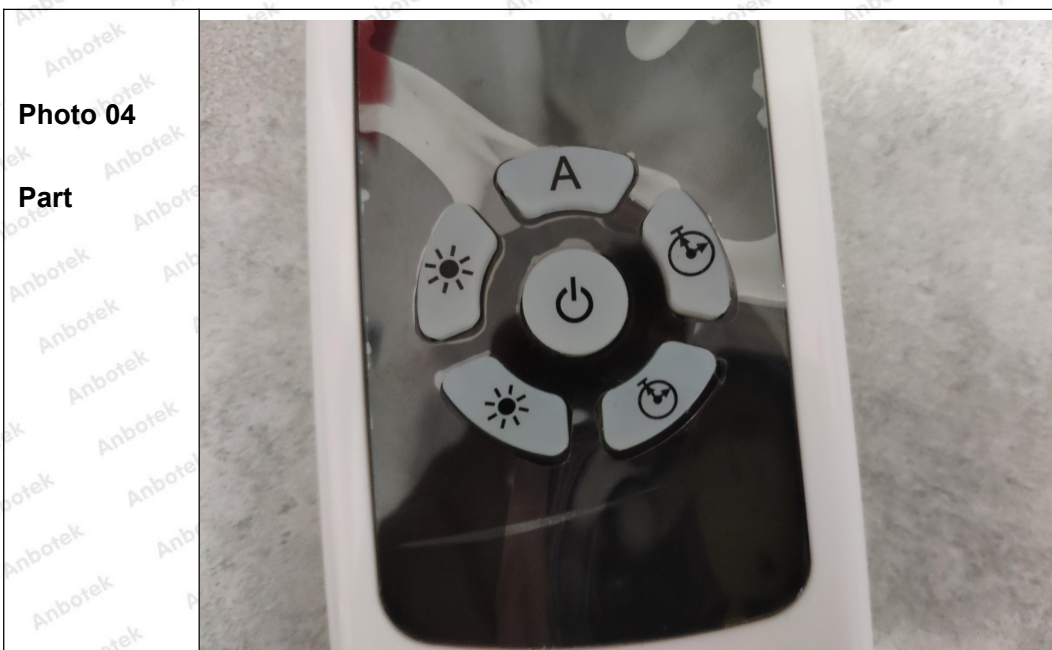


Photo of Voltage Dips and Interruptions Test



APPENDIX II -- PHOTOGRAPH





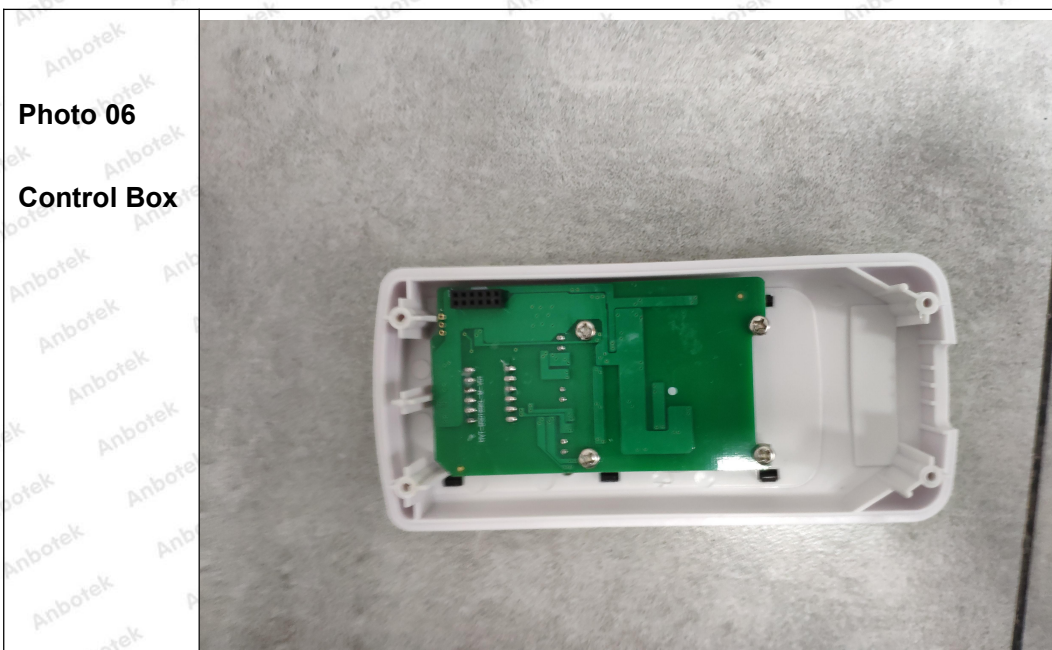


Photo 07

Internal

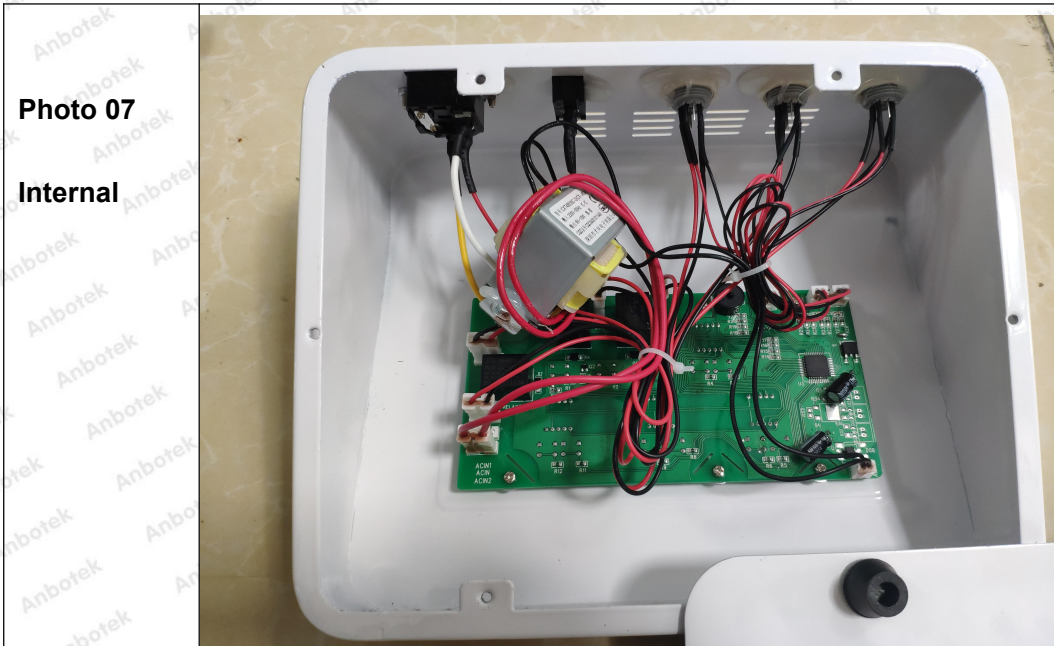
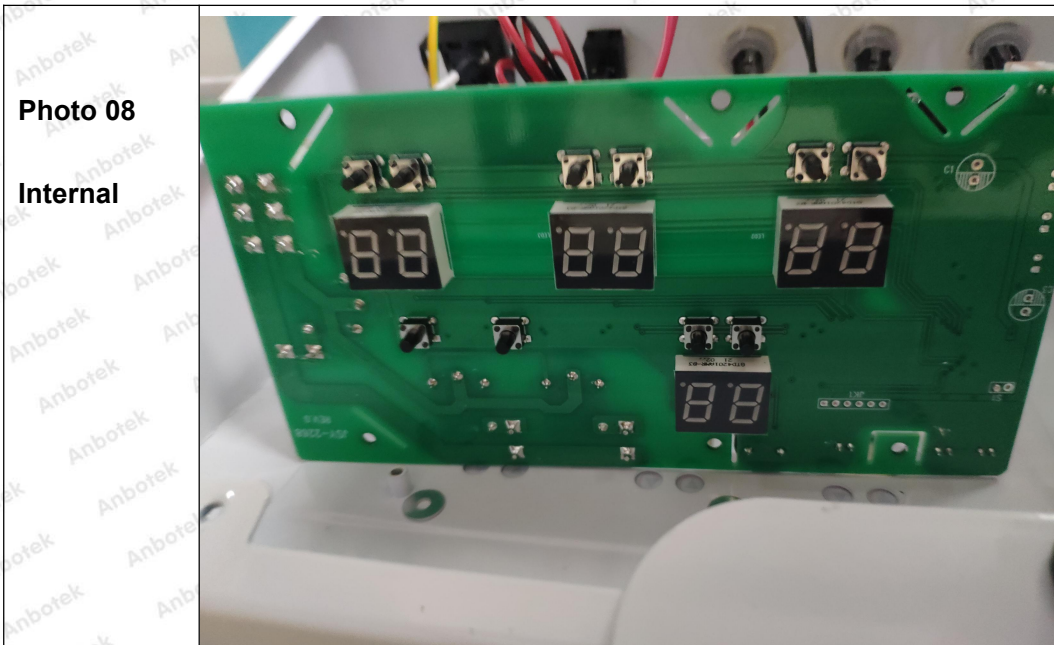


Photo 08

Internal



CE Label

1. The CE conformity marking must consist of the initials 'CE' taking the following form:

If the CE marking is reduced or enlarged, the proportions given in the above graduated drawing must be respected.

2. The CE marking must have a height of at least 5 mm except where this is not possible on account of the nature of the apparatus.

3. The CE marking must be affixed to the product or to its data plate. Additionally it must be affixed to the packaging, if any, and to the accompanying documents.

4. The CE marking must be affixed visibly, legibly and indelibly.

It must have the same height as the initials 'CE'.

----- End of Report -----